



RG 3

Blank-Signal Pistol cal. 6 mm

Flobert Platz

EN	Operating instructions	2 - 11
DE	Bedienungsanleitung	12 - 21
FR	Mode d'emploi	22 - 31
ES	Manual de instrucciones	32 - 41
TR	Kullanım Kilavuzu	42 - 51
RU	Инструкция по эксплуатации	52 - 61

1



SAFETY INSTRUCTIONS

2



CARE

3



DESIGNATION OF PARTS

4



OPERATION



SAFE WEAPON HANDLING

EN

You should be fully familiar with the proper and safe handling of your weapon. Remember that according to the basic rules of safe weapon handling, touching a gun is the same as handling it.

- Always treat a weapon as if it was loaded.
- Always keep the pistol on "Safe" when loading it in order to prevent an unintentional discharge.
- Keep your finger away from the trigger. It should be straight and should rest on the trigger guard.
- Only use the kind of ammunition suitable for your weapon.
- Always keep the muzzle pointed in a safe direction.
- Never transport a loaded weapon. Only load your weapon when you intend to fire it.
- Never aim your blank firing gun at persons or animals.
- Before you discharge your weapon, make sure that target and surrounding area are safe.
- Always check whether the weapon is unloaded when you are carrying it or when you have received it from another person.
- Make sure that you always have full control over the muzzle of your weapon, even if you stumble or fall down.
- Safety shooting glasses should always be worn when firing the weapon.
- Always store your weapon in a safe place and in unloaded condition. Unauthorized persons (persons not familiar with the use of weapons, children and minors) must not have access to it. Ammunition must be kept in a separate place.
- The weapon together with its operating instructions may only be handed over to persons who have reached the age of 18 (or older) and who are fully familiar with the handling of it.
- Modifications or repairs of weapons are only to be effected by authorized agencies or by a skilled gunsmith.
- Never leave a loaded weapon unattended.
- Only unloaded weapons are to be handed over to another person.
- Shooting with a blank firing weapon is permitted only under the following circumstances (for more details refer to the applicable firearms laws in your country)
 - averting danger and performing rescue training
 - for self-defense and in states of emergency
 - shooting on enclosed private property by the owner or with the owner's permission.



CAUTION

The legal requirements set forth in these operating instructions relate exclusively to Germany. Please comply carefully with the firearms laws in your own country!



SAFETY INSTRUCTIONS

EN

WARRANTY

During the legal warranty period, which begins on the date of purchase, Umarex Sportwaffen GmbH & Co. KG will repair or replace your weapon at no charge provided the defect was not caused by you. Return your weapon to an authorized dealer along with a description of the problem and proof of purchase.

The blank, gas and signal weapons manufactured by the company Umarex Sportwaffen GmbH & Co. KG are made according to the homologation regulations of the "Physikalisch-Technische Bundesanstalt" (PTB), German federal law, the CIP regulations and the technical know-how of Umarex Sportwaffen GmbH & Co. KG.

We shall not assume any liability whatsoever if our products are exported to territories outside Germany and as a consequence do not comply with domestic legal requirements of these territories. It shall be the sole responsibility of the importer to ensure compliance with local laws and regulations.



CAUTION

Carefully read and understand these instructions before using this weapon. Buyers and users must follow the instructions for the safe use of blank/gas/signal weapons. Any changes or modifications of this weapon will lead to a different classification of the weapon in respect of the appropriate firearms legislation and are therefore illegal. In such cases, the manufacturer's warranty becomes immediately null and void.

You must be 18 years or older to purchase this blank/gas/signal pistol.



SAFETY INSTRUCTIONS



CARE

EN

CARE

Clean your pistol each time after using it. Clean the cartridge chamber, breech face and magazine lips using weapon oil, a brush and a soft cloth.

REPAIR

Do not attempt to repair this pistol if it needs service. Incorrect assembly could lead to dangerous malfunctions.



CAUTION

Repairs should only be made by Umarex authorized centers.

TECHNICAL DATA

System:	blank/gas/signal pistol	Width:	24,5 mm
Trigger:	Double Action Only	Height:	80 mm
Ammo:	blank/irritant cartridges	Weight:	335 g
Caliber:	cal. 6 mm Flobert	Magazine capacity:	6 rounds
Length:	105 mm	Safety:	manual



DESCRIPTION OF PARTS

EN

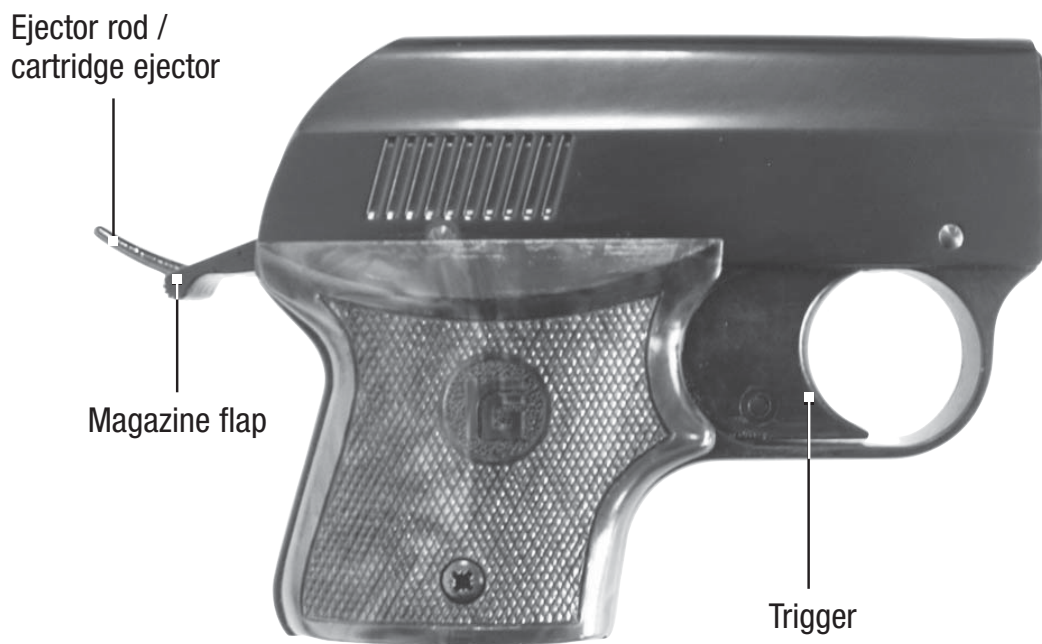



SAFETY / FIRING / UNLOADING

EN



CAUTION

Only handle the pistol when it is in the decocked condition.
Always make sure that the muzzle is pointing in a safe direction.

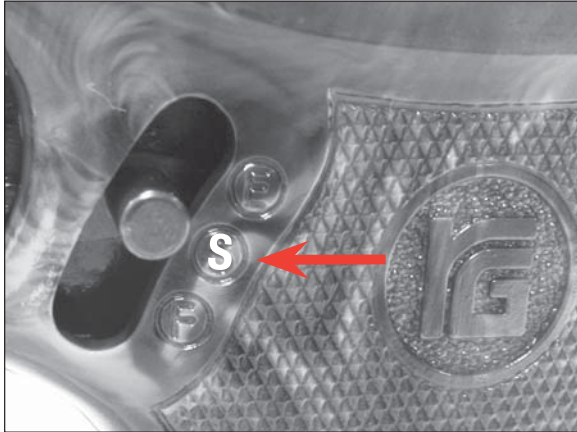

Safety

Push safety to position **S**.

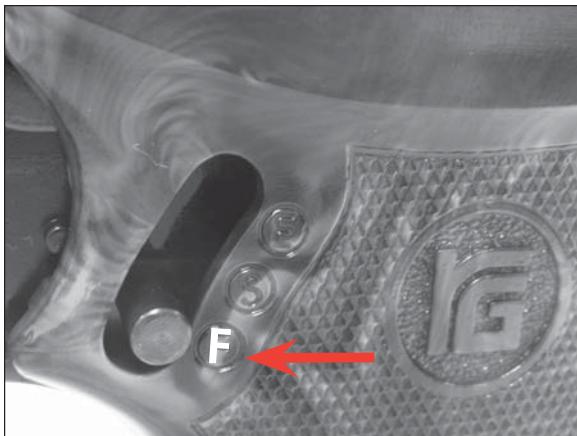

Shooting

Push safety catch to position **F**. Pull trigger until the shot goes off. Let trigger get back to normal position and the pistol can be fired again. After 6 rounds the magazine will be empty. Pulling the trigger once more will eject the magazine.

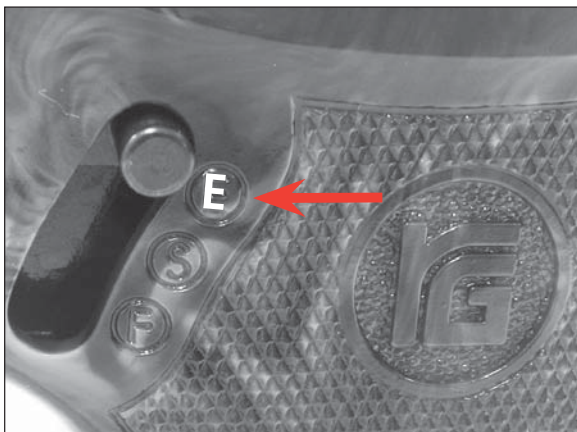

Unloading

Push safety catch to position **E**. Pull trigger until the magazine and push out empty shells.



LOADING

EN



CAUTION

Use only cal. 6 mm Flobert blank or irritant ammunition.
Load, unload and strip the weapon only when the safety is engaged.
Always keep the muzzle pointed in a safe direction.



❶ Remove the empty magazine.



❷ Pull up the steel flap on the magazine.

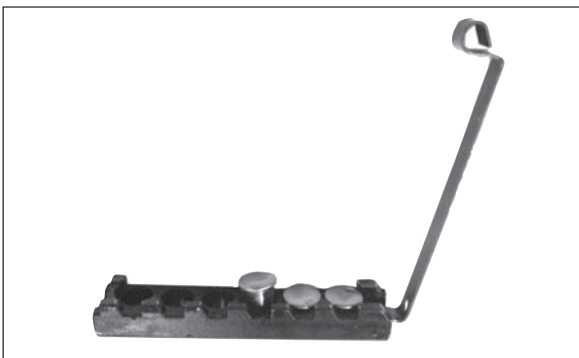

❸ Insert cartridges cal. 6mm Flobert.

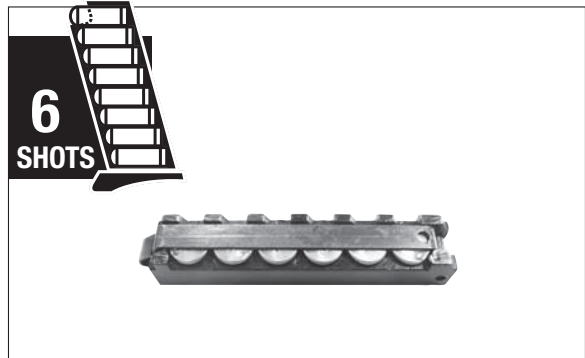

❹ Press down the steel flap.



❺ Insert the loaded magazine into the magazine channel from the muzzle side until it clicks into the position.



FIRING BLANK AMMUNITION / IRRITANTS

EN

Double Action Only

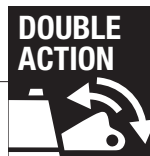

Pulling the trigger cocks the hammer and the shot is fired.



TO EJECT EMPTY SHELLS



Swing out ejector at the locking flap, open flap on the magazine and push out empty shells.



FIRING SIGNALLING AMMUNITION

EN

Use only a fireworks adapter with the following PTB identification:

PTB
33

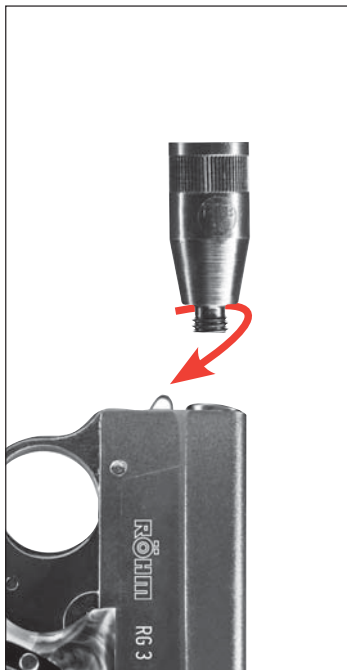

Screw the fireworks adapter into the barrel. Load the pistol with blanks.



Insert signalling ammunition into the fireworks adapter with the open (black) end of the casing first.



Point the gun straight up above your head when shooting.



CAUTION

The operator must maintain a distance of at least 2 meters from any other persons.



ACCESSORIES

EN

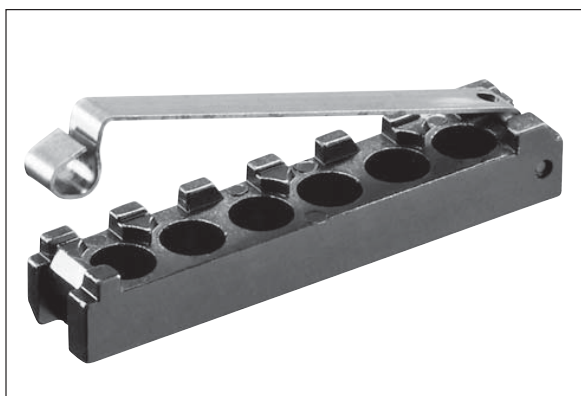

Magazine



Grip plate left (plastic)



Grip plate right (plastic)

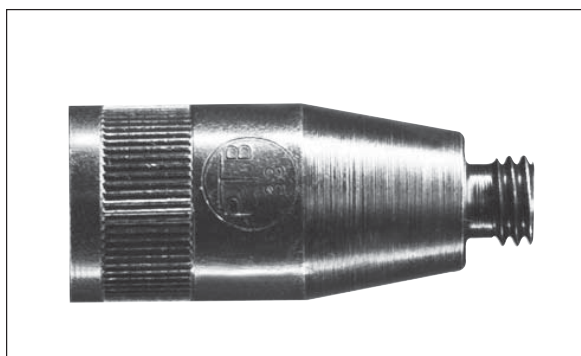

Fireworks adapter PTB-Nr.: 33



SICHERHEITSHINWEISE



PFLEGE



BENENNUNG DER TEILE



BEDIENUNG



Sie sollten mit der richtigen, sicheren Handhabung Ihrer Waffe vertraut sein. Im Hinblick auf die Grundregeln zum sicheren Schießen bedenken Sie, dass jede Berührung mit der Waffe als Handhabung verstanden wird.

- Behandeln Sie jede Waffe so, als wäre sie geladen.
- Die Waffe beim Laden stets sichern, so dass sich kein Schuss ungewollt lösen kann.
- Finger immer außerhalb des Abzugsbügels halten und nur zum Schuss an den Abzug legen.
- Verwenden Sie nur für diese Waffe vorgesehene Munition.
- Halten Sie die Mündung stets in eine sichere Richtung.
- Transportieren Sie niemals eine geladene Waffe. Laden Sie nur, wenn Sie schießen möchten.
- Waffe niemals auf Menschen oder Tiere richten.
- Vergewissern Sie sich vor dem Schuss, dass Ziel und Umgebungsbereich sicher sind.
- Kontrollieren Sie immer, ob die Waffe ungeladen ist, wenn Sie sie transportieren oder von einer anderen Person übernehmen.
- Vergewissern Sie sich, dass Sie, auch beim Stolpern oder Stürzen die Richtung der Mündung kontrollieren können.
- Aus Sicherheitsgründen sollte beim Schießen eine Schutzbrille getragen werden.
- Aufbewahren der Waffe stets sicher und ungeladen vor unerlaubtem Zugriff Unbefugter (ungeschulte Personen, Kinder, Personen unter 18 Jahren) und getrennt von der Munition.
- Weitergabe dieser Waffe mit der Bedienungsanleitung nur an Personen, wenn diese über 18 Jahre alt und mit der Handhabung dieser Waffe genauestens vertraut sind.
- Jegliche Veränderungen oder Reparaturen von Waffen sollten nur von fachkundigen Firmen oder vom Büchsenmacher durchgeführt werden.
- Legen Sie niemals eine geladene Waffe aus der Hand.
- Geben Sie nur entladene Waffen an andere Personen weiter.
- Das Schießen mit Schreckschusswaffen ist nur erlaubt (näheres siehe § 12 Waffengesetz):
 - zur Gefahrenabwehr und bei Rettungsübungen
 - in den Fällen der Notwehr und des Notstandes
 - und durch den Inhaber des Hausrechtes oder mit dessen Zustimmung im befriedeten Besitztum.
- Zum Führen der Schreckschußwaffe benötigen sie den sog. „Kleinen Waffenschein“



ACHTUNG

Die in dieser Bedienungsanleitung genannten Gesetzesangaben beziehen sich ausschließlich nur auf Deutschland. Bitte beachten Sie das jeweilige Waffengesetz in Ihrem Land!



GARANTIE

Innerhalb des gesetzlich festgelegten Zeitraumes repariert oder ersetzt Ihnen die Firma UMAREX Sportwaffen GmbH & Co. KG Ihre Waffe kostenlos, falls der Defekt nicht durch Eigenverschulden aufgetreten ist. Geben Sie die Waffe einem autorisierten Händler, beschreiben Sie ihm das Problem und fügen Sie den entsprechenden Kaufbeleg bei.

Die von Firma UMAREX Sportwaffen GmbH & Co. KG hergestellten Schreckschuss-/ Reizstoff-/Signalwaffen werden gemäß dem Bundesgesetz, den CIP-Vorschriften und dem waffentechnischen Know-how der Firma UMAREX Sportwaffen GmbH GmbH & Co. KG hergestellt.

Somit übernehmen wir keine Haftung, falls diese Ware nach dem Export ins Ausland nicht den dort geltenden Rechtsvorschriften entsprechen sollte und dem Besitzer/Käufer juristische Schwierigkeiten und deren Konsequenzen entstehen sollten.



ACHTUNG

Zu Ihrer eigenen und zur Sicherheit anderer lesen Sie die Bedienungsanleitung vollständig und sorgfältig durch, bevor Sie mit der Waffe den ersten Versuch zu Schießen unternehmen. Käufer und Besitzer haben die Pflicht, alle Regeln über den Gebrauch und den Besitz von Schreckschuss-/ Reizstoff- und Signalwaffen zu befolgen. Jede Änderung an dieser Waffe kann zu einer Änderung der waffenrechtlichen Einstufung führen und ist somit unzulässig. Die Gewährleistung des Herstellers erlischt in diesem Fall sofort.

Diese Schreckschuss-/Reizstoff- und Signal-Pistole ist frei erwerbbar ab 18 Jahren oder älter.



PFLEGE

Pflegen Sie die Waffe nach jedem Gebrauch. Mit Hilfe von Waffenöl, der Reinigungsbürste und eines weichen Tuches reinigen Sie das Patronenlager, den Stoßboden und die Magazinlippen.

REPARATUR

Eine Waffe, die nicht einwandfrei funktioniert, ist gefährlich. Es ist schwierig, eine Waffe selbst zu reparieren, und ein falscher Zusammenbau kann zu gefährlichen Funktionsstörungen führen.



ACHTUNG

Lassen Sie die Waffe nur von einem autorisiertem Fachhändler/ Büchsenmacher überprüfen und reparieren.

TECHNISCHE DATEN

System:	Gas-Signal-Pistole	Breite:	24,5 mm
Abzug:	Double Action Only	Höhe:	80 mm
Munition:	Platz- / Reizstoffpatronen	Gewicht:	335 g
Kaliber:	cal. 6 mm Flobert	Magazinkapazität:	6 Schuss
Länge:	105 mm	Sicherung:	manuell



BENENNUNG DER TEILE

DE

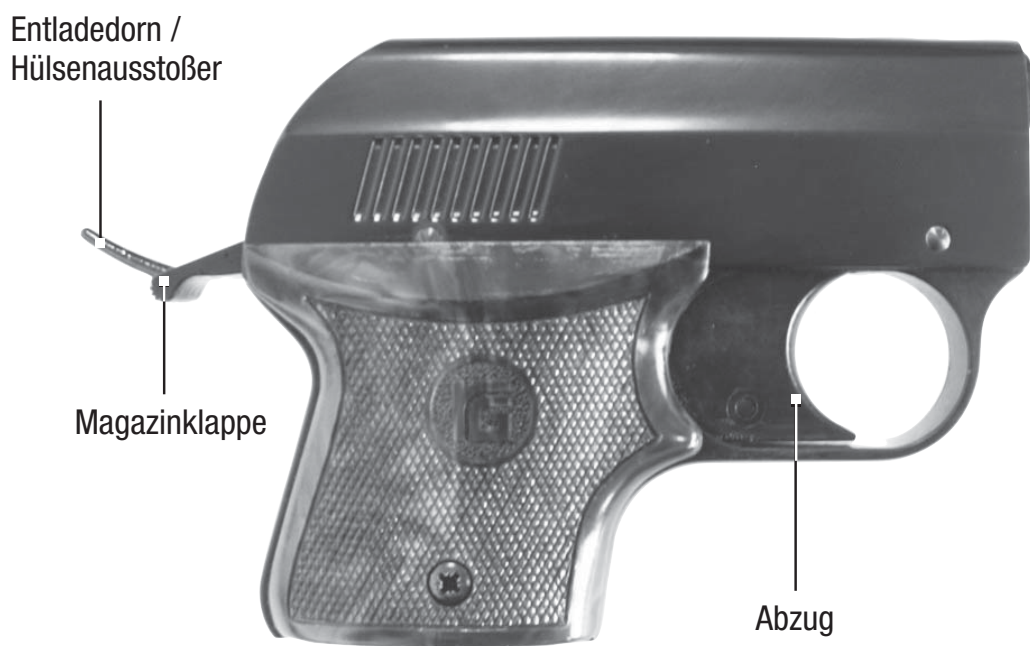



SICHERN / SCHIESSEN / ENTLADEN

DE



ACHTUNG

Hantieren Sie nur mit der Waffe, wenn diese gesichert ist.
Achten Sie stets darauf, dass die Mündung in eine sichere Richtung zeigt.

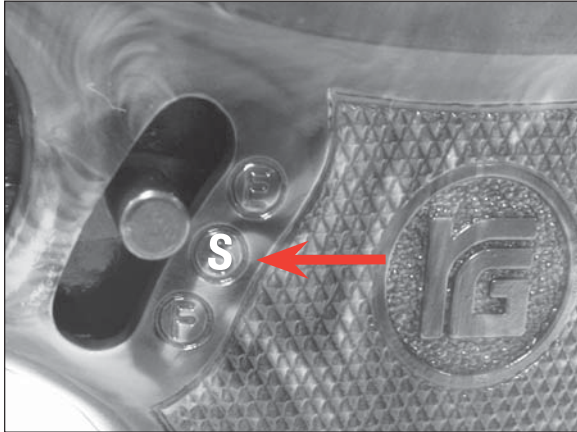

Sichern

Sicherungshebel in die Mitte auf Stellung **S** schieben.

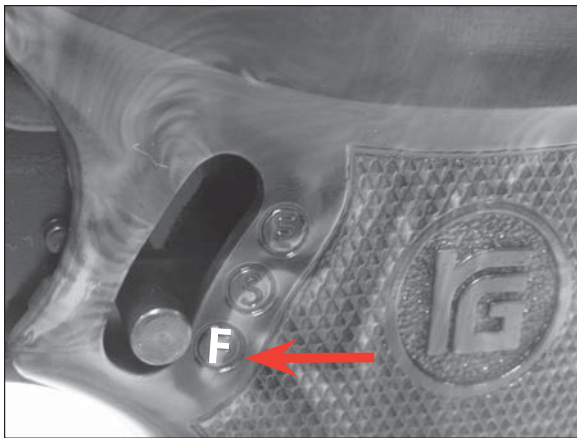

Schießen

Sicherungshebel auf Stellung **F** schieben. Abzug ganz durchziehen. Nach Rückkehr des Abzugs in die Ausgangsstellung ist die Pistole wieder schußbereit. Nach 6 Schuß ist das Magazin leer, beim nochmaligen Durchziehen fällt das Magazin heraus.

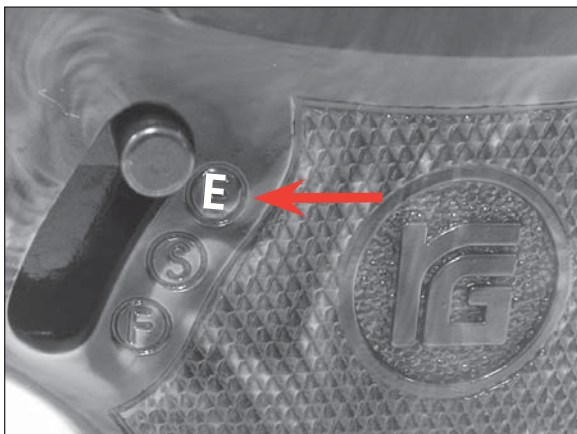

Entladen

Sicherungshebel auf Stellung **E** schieben. Abzug wiederholt durchziehen, bis sich das Magazin entnehmen läßt.



LADEN

DE



ACHTUNG

Nur Platz-, bzw. Reizstoffmunition cal. 6 mm Flobert Platzpatronen verwenden.
Die Pistole nur im gesichertem Zustand laden, entladen und demontieren.
Dabei die Laufmündung immer nach unten halten.



❶ Leeres Magazin entnehmen.



❷ Patronenhalter am Magazin hochklappen.

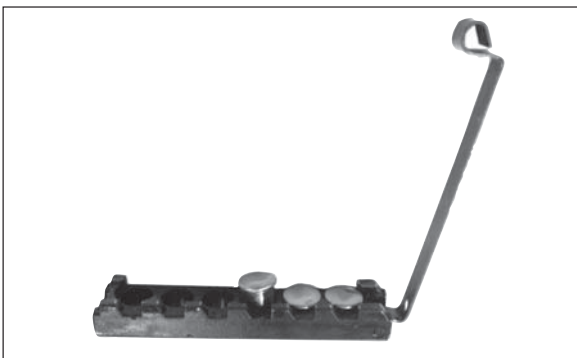

❸ Patronen cal. 6mm Flobert in Magazin einlegen.

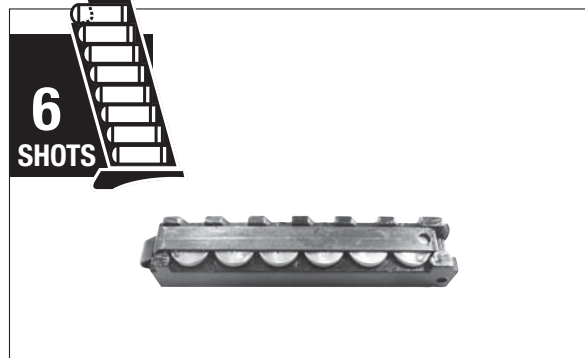

❹ Halter schließen.



❺ Gefülltes Magazin von vorne in den Magazinkanal der Pistole bis zum Einrasten einführen.



PLATZ- / REIZSTOFFMUNITION SCHIESSEN

DE

Spannabzugssystem - (Double Action Only)

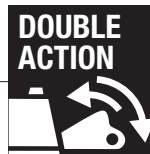

Abzug betätigen.



ENTFERNEN ABGEFEUERTER PATRONENHÜLSEN



Entladedorn an der Magazinklappe ausschwenken, Patronenhalter am Magazin hochklappen und mit dem Entladedorn die Patronenhülsen ausstoßen.



SIGNALMUNITION SCHIESSEN

DE

Nur Abschussbecher mit folgender PTB-Kennzeichnung verwenden:

PTB
33

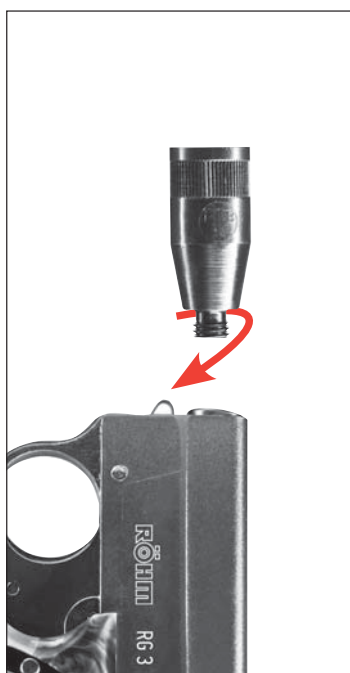

Abschussbecher in den Lauf einschrauben. Waffe mit Platzmunition laden.

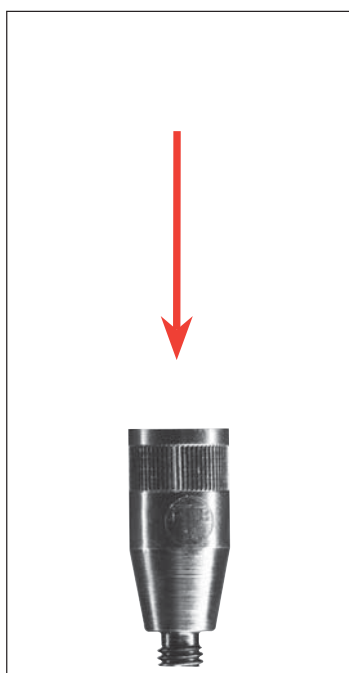

Signalmunition mit dem offenen (schwarzen) Hülsenende zuerst in den Abschussbecher einführen.



Waffe beim Schießen senkrecht über den Kopf halten.



ACHTUNG

Der Schießende muss zu umstehenden Personen einen Abstand von mindestens 2 m einhalten.

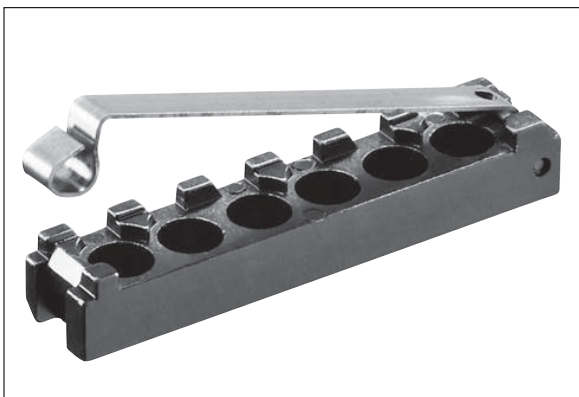

Magazin



Plastikgriffschale links



Plastikgriffschale rechts

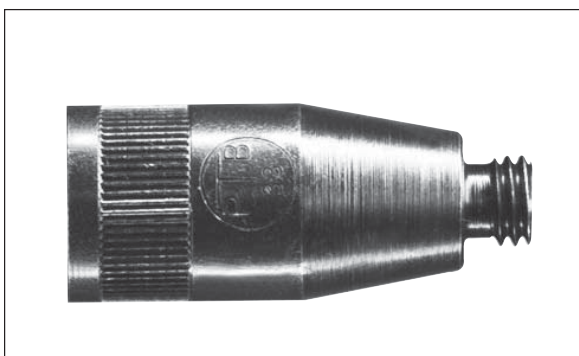

Abschussbecher PTB-Nr.: 33

1



CONSIGNES DE SÉCURITÉ

2



ENTRETIEN

3



DÉSIGNATION DES PIÈCES

4



UTILISATION



MANIEMENT DES ARMES EN TOUTE SÉCURITÉ

FR

Vous devez être habitué à manipuler votre arme correctement et de manière sûre. En considération des règles de base pour tirer en toute sécurité, n'oubliez pas que tout contact avec l'arme est considéré comme une manipulation.

- Maniez toujours l'arme comme si elle était chargée.
- Enclenchez toujours la sûreté avant de charger l'arme afin d'éviter tout tir involontaire.
- Ne mettez jamais le doigt sur la détente avant d'être prêt à tirer.
- Utilisez seulement les munitions prévues pour cette arme.
- Pointez toujours l'arme dans une direction sûre.
- Ne transportez jamais une arme chargée. Armez-la seulement lorsque vous êtes prêt à tirer.
- Ne pointez jamais l'arme vers des personnes ou des animaux.
- Avant de tirer, assurez-vous que la cible et les alentours ne présentent aucun danger.
- Vérifiez toujours que l'arme est déchargée avant de la transporter ou lorsque vous la recevez d'autrui.
- Veillez à maîtriser la direction dans laquelle l'arme est pointée même si vous trébuchez ou tombez.
- Pour des raisons de sécurité, portez des lunettes de protection lorsque vous tirez.
- Rangez toujours l'arme déchargée, avec la sûreté enclenchée, séparée des munitions, et hors de portée des personnes non autorisées (personnes non formées au maniement, enfants, mineurs).
- Remettez cette arme accompagnée du mode d'emploi seulement à des personnes de plus de 18 ans et le plus possible formées au maniement de cette arme.
- Toute modification ou réparation de l'arme doit être effectuée par une entreprise spécialisée ou un armurier.
- Ne posez jamais une arme chargée.
- Déchargez toujours l'arme avant de la remettre à d'autres personnes.
- Le tir avec des armes d'alarme n'est autorisé que dans les cas suivants (pour de plus amples informations, se reporter à la loi sur les armes en vigueur dans votre pays) :
 - en cas de menace et lors d'exercices de sauvetage
 - en cas de légitime défense et de situations d'urgence
 - pour une utilisation par le propriétaire ou avec son autorisation dans une propriété sécurisée.



ATTENTION

Les indications légales indiquées dans ce mode d'emploi se réfèrent exclusivement à l'Allemagne. Veillez à respecter la législation s'appliquant aux armes dans votre pays !



GARANTIE

La société Umarex Sportwaffen GmbH & Co. KG s'engage à réparer ou à remplacer votre arme durant une période déterminée légalement à compter de la date d'achat, à condition que vous ne soyez pas responsable du défaut. Pour cela, remettez l'arme à un revendeur autorisé, décrivez-lui le problème et joignez le justificatif d'achat correspondant.

Les armes d'avertissement, lacrymogènes et d'alarme de la société UMAREX Sportwaffen GmbH & Co. KG sont fabriquées conformément aux directives de conformité de l'institut allemand « Physikalisch-Technische Bundesanstalt (PTB) », à la loi fédérale, aux prescriptions CIP et au savoir-faire technique de la société UMAREX Sportwaffen GmbH & Co. KG dans le domaine des armes.

Ainsi, nous ne pouvons être tenus responsables si, après exportation à l'étranger, cette marchandise ne répond pas aux prescriptions légales en vigueur dans le pays en question et si le possesseur/acheteur doit pour cette raison faire face à des difficultés juridiques ou toute autre conséquence pouvant découler de ce fait.



ATTENTION

Pour votre sécurité et celle des autres, veuillez lire attentivement tout le mode d'emploi avant de tirer pour la première fois avec cette arme. Les acheteurs et détenteurs d'armes ont l'obligation de respecter toutes les règles relatives à l'utilisation et à la possession d'armes d'avertissement, lacrymogènes et d'alarme. Il est interdit de modifier l'arme, ceci pouvant entraîner un changement de classification légale de l'arme. En cas de non-respect de cette règle, la garantie du fabricant expire immédiatement.

Cette arme d'avertissement / lacrymogène / d'alarme est en vente libre pour les personnes majeures.



ENTRETIEN

Nettoyez l'arme avant toute utilisation. Nettoyez le chargeur, le fond de butée et les lèvres du chargeur avec de l'huile pour armes, une brosse de nettoyage et un chiffon doux.

RÉPARATION

Une arme qui ne fonctionne pas parfaitement est dangereuse. Il est difficile de réparer une arme soi-même, et un remontage incorrect peut entraîner des dysfonctionnements dangereux.



ATTENTION

Seules des personnes spécialisées agréées ou un armurier peuvent contrôler et réparer l'arme.

CARACTÉRISTIQUES TECHNIQUES

Système :	Pistolet d'avertissement / lacrymogène / d'alarme	Longueur :	105 mm
		Largeur :	24,5 mm
		Hauteur :	80 mm
Détente :	Double Action Only	Poids :	335 g
Munitions :	Cartouches à blanc / irritantes	Capacité :	6 tirs
Calibre :	cal. 6 mm Flobert	Sécurité :	manuelle



DÉSIGNATION DES PIÈCES

FR

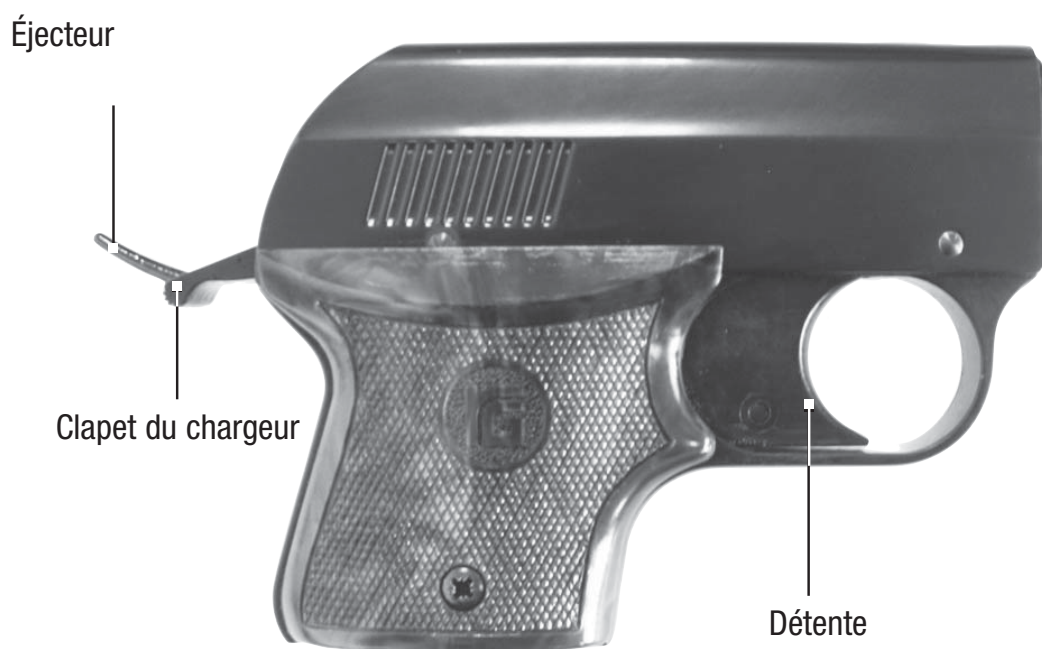



ATTENTION

Ne manipulez l'arme que lorsque la sûreté est enclenchée.
Veillez à toujours pointer la bouche de l'arme dans une direction sûre.

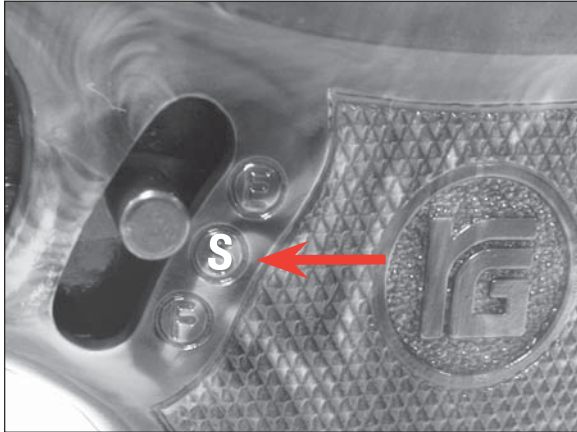

Enclenchez la sûreté

Placez le levier de sûreté au centre, sur la position **S**.

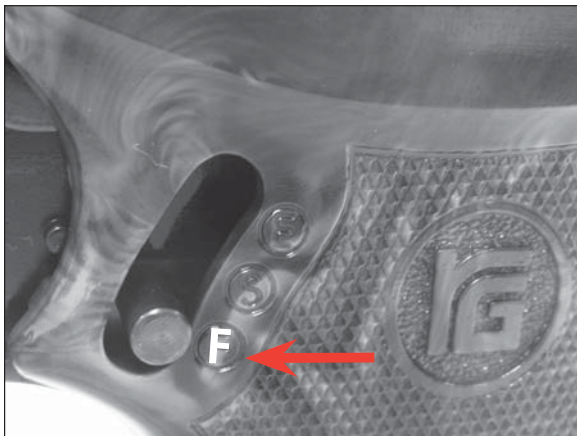

Tir

Poussez le levier de sûreté en position **F**. Appuyez à fond sur la détente. Une fois la détente revenue dans sa position initiale, le pistolet est à nouveau prêt à tirer. Après 6 coups, le chargeur est vide et sort si l'on appuie une nouvelle fois sur la détente.

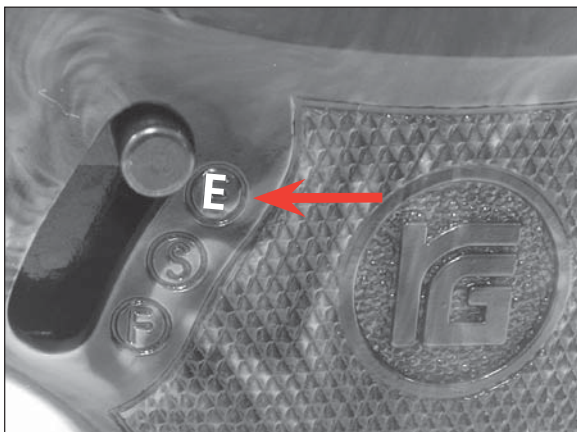

Déchargement

Poussez le levier de sûreté en position **E**. En appuyant une nouvelle fois sur la détente, le chargeur est expulsé par l'arrière.



CHARGEMENT

FR



ATTENTION

N'utilisez que des munitions à blanc ou irritantes de cal. 6 mm Flobert
Enclenchez impérativement la sûreté avant de charger, décharger et démonter l'arme.
Ce faisant, pointez toujours la bouche de l'arme vers le bas.



❶ Retirez le chargeur vide.



❷ Soulevez le couvercle du chargeur.

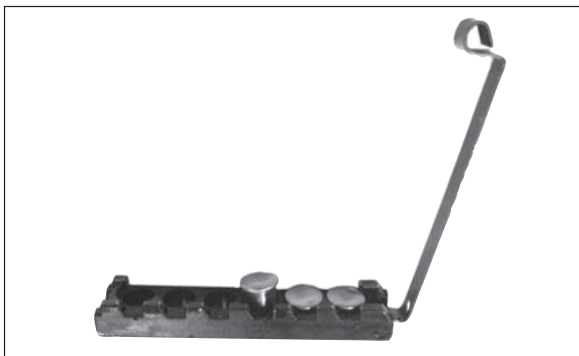

❸ Insérez les munitions 6 mm Flobert dans le chargeur.

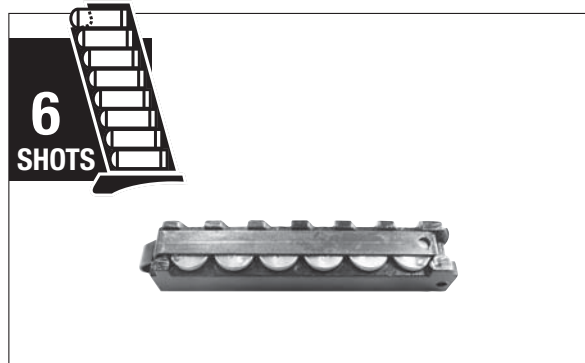

❹ Fermez le couvercle.



❺ Insérez par l'avant le chargeur plein dans le logement du pistolet jusqu'à ce qu'il s'enclenche.



TIRER DES MUNITIONS À BLANC/IRRITANTES

FR

Systeme de détente à double action (Double Action Only)

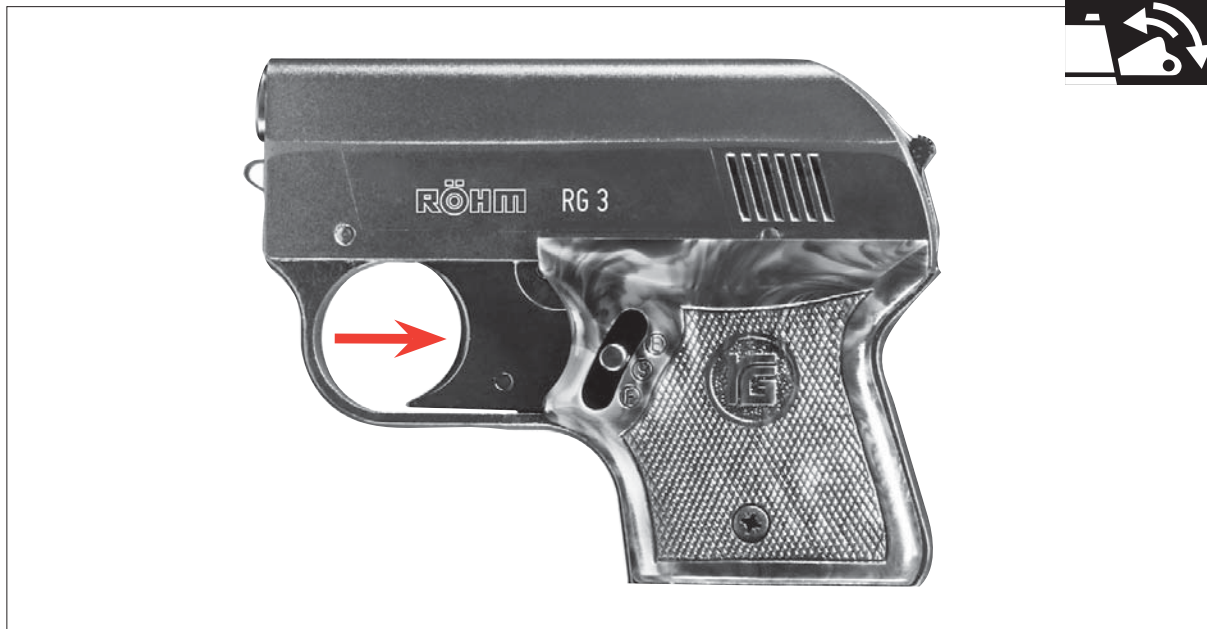
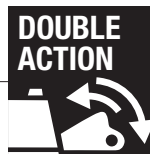

Actionnez la détente



RETRAIT DES CARTOUCHES VIDES



Faites pivoter l'éjecteur sur le clapet du chargeur, ouvrez le couvercle du chargeur et retirez les cartouches vides à l'aide de l'éjecteur.



TIRER DES MUNITIONS DE SIGNALISATION

FR

Utilisez uniquement des adaptateurs de tir portant la désignation PTB (laboratoire allemand national des normes) suivante :

PTB
33

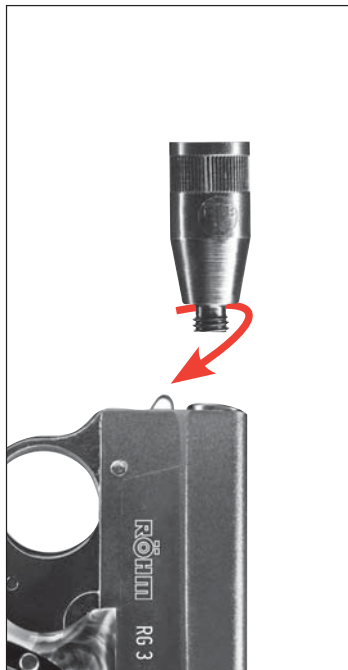

Vissez l'adaptateur de tir sur le canon.
Chargez l'arme avec des munitions à blanc.



Introduisez la munition de signalisation dans l'adaptateur de tir, extrémité ouverte (noire) en premier.



Lors du tir, tenez l'arme à la verticale au-dessus de votre tête.



ATTENTION

Le tireur doit se tenir à au moins 2 m des personnes l'entourant.

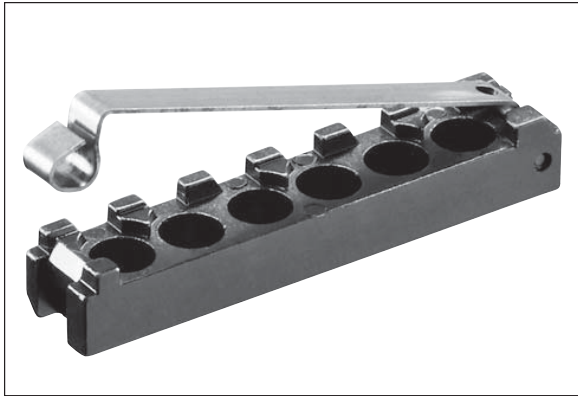

Chargeur



Plaquette de poignée en plastique, gauche



Plaquette de poignée en plastique, droite



Adaptateur de tir, réf PTB : 33

1



INSTRUCCIONES DE SEGURIDAD

2



CUIDADOS

3



DENOMINACIÓN DE LAS PIEZAS

4



REGLAJE



Deberá estar familiarizado con el manejo correcto y seguro de su arma. Con respecto a las reglas básicas para disparar con seguridad, considere cada contacto con el arma como parte de su manejo.

- Trate siempre el arma como si estuviera cargada.
- Al cargar el arma, asegúrese de que tenga el seguro activado para evitar que se dispare involuntariamente.
- Mantenga el dedo siempre fuera del guardamonte y colóquelo solamente cuando vaya a disparar.
- Use únicamente la munición prevista para esta arma.
- Mantenga la boca del arma siempre en una dirección segura.
- Nunca transporte el arma cargada. Cárguela solamente cuando tenga intención de disparar.
- Nunca apunte el arma hacia personas o animales.
- Antes de disparar, asegúrese de que el objetivo y el entorno sean seguros.
- Al transportar o recibir el arma de otra persona, compruebe siempre que esté descargada.
- Asegúrese siempre de que, aunque tropezara o cayera, todavía puede controlar la dirección a la que apunta la boca del arma.
- Por motivos de seguridad, deberá usar siempre gafas protectoras cuando vaya a disparar.
- Al guardar el arma asegúrese siempre de que está descargada y con el seguro activado, separada de la munición y lejos del alcance de personas no autorizadas (personas no instruidas y personas menores de 18 años).
- Entregue esta arma, junto con las instrucciones de uso, únicamente a aquellas personas mayores de 18 años que estén perfectamente familiarizadas con su manejo.
- Cualquier modificación o reparación del arma deberá llevarla a cabo una empresa especializada o un armero.
- Nunca deje sin vigilancia un arma cargada.
- Siempre que entregue un arma a otra persona, asegúrese de que está descargada.
- El disparo de armas de alarma solo está permitido en los siguientes casos (para mayor información consulte por favor la ley de armas vigente en su país):
 - Para rechazar peligros y en ensayos de salvamento
 - En caso defensa propia y de emergencia
 - Y por parte del titular del derecho doméstico o con su autorización en lugar cerrado



ATENCIÓN

Las disposiciones legales mencionadas en estas instrucciones de uso se refieren única y exclusivamente a la República Federal de Alemania. Rogamos observe en todo caso la legislación vigente en su país sobre el uso de armas.



GARANTÍA

La empresa Umarex Sportwaffen GmbH & Co. KG se responsabiliza de reparar o sustituir su producto sin coste alguno en el plazo legalmente fijado a partir de la fecha de compra, siempre que el defecto no sea responsabilidad del propio usuario. Entregue el arma a un comerciante autorizado, descríbele el problema y adjunte el correspondiente comprobante de compra.

Las armas de alarma, de señalización y de gases lacrimógenos fabricadas por la empresa Umarex Sportwaffen GmbH & Co. KG se fabrican de conformidad con las normas de homologación del Instituto Federal PTB (Physikalisch-Technischer Bundesanstalt), con la Ley Federal alemana, la normativa que establece el centro CIP y la experiencia en fabricación de armas de la empresa Umarex Sportwaffen GmbH & Co. KG.

Por eso, no asumimos ninguna responsabilidad en el caso de que al exportar el arma a un país extranjero, ésta no cumpliera con la normativa legal local y el propietario o comprador tuviera que responder jurídicamente por dicho incumplimiento.



ATENCIÓN

Por su propia seguridad y la de los demás, lea detenidamente las instrucciones de uso completas antes de disparar el arma por primera vez. Compradores y propietarios están obligados a cumplir todas las normas de uso y posesión de armas de alarma, gases lacrimógenos y señales. Queda prohibida cualquier modificación de esta arma, ya que ello podría implicar un cambio en su clasificación legal. En caso de modificación quedaría extinguida de inmediato la garantía del fabricante.

La venta de esta arma de alarma/arma de gases lacrimógenos/arma de señales es libre a personas mayores de 18 años.



CUIDADOS

Limpie el arma después de usarla. Limpie la recámara, la cara de la recámara y los labios del cargador con aceite para armas, cepillo de limpieza y un trapo suave.

REPARACIONES

Un arma que no funcione perfectamente es peligrosa. Es difícil reparar uno mismo un arma, y un ensamblaje incorrecto puede producir anomalías de funcionamiento peligrosas.



ATENCIÓN

La comprobación y reparación del arma deberán dejarse en manos de especialistas autorizados o un armero.

ESPECIFICACIONES

Sistema:	Pistola de alarma / pistola de gases lacrimógenos/pistola de señalización	Longitud:	105 mm
		Ancho:	24,5 mm
		Altura:	80 mm
Gatillo:	Double Action Only	Peso:	335 g
Munición:	Cartuchos de fogeo/irritantes	Capacidad del cargador:	6 disparos
Calibre:	cal. 6 mm Flobert	Seguro:	manuel



DENOMINACIÓN DE LAS PIEZAS / DATOS TÉCNICOS **ES**

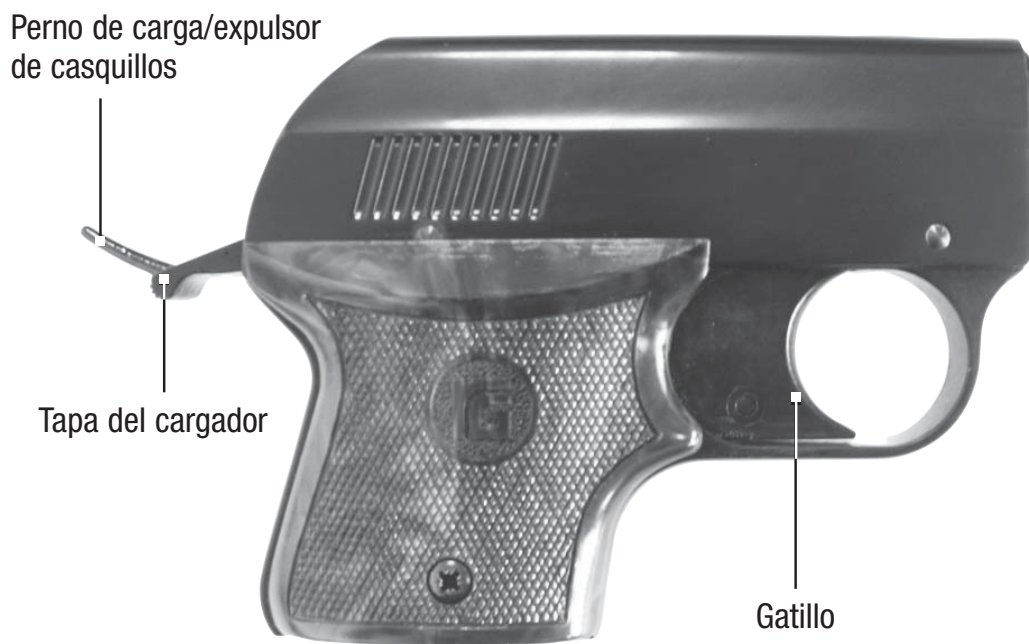



ACTIVAR EL SEGURO / DISPARAR / DESCARGAR

ES



ATENCIÓN

Manipule la pistola únicamente cuando tenga el seguro activado.
Procure que la boca del cañón apunte siempre en una dirección segura.

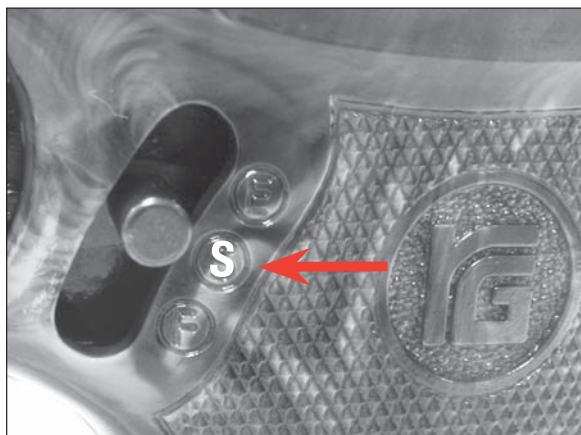

Activar el seguro

Coloque la palanca del seguro en el centro,
en posición **S**

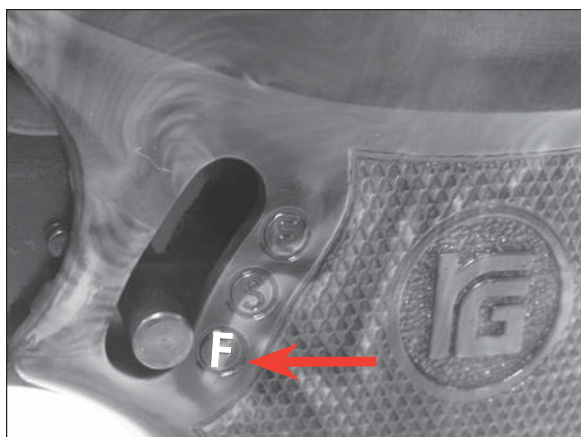

Disparar

Colocar la palanca del seguro en posición **F**
Accionar el gatillo por completo. La pistola
está ne nuevo lista para disparar cuando el
gatillo regrese a su posición original. Tras
realizar 6 disparos el cargador queda vacío,
si vuelve a disparar se caerá el cargador.

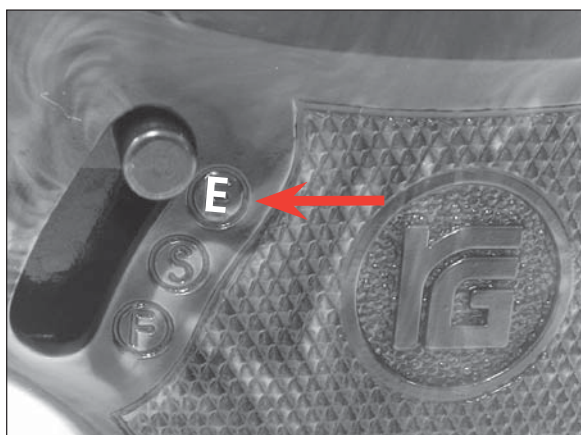

Descargar

Colocar la palanca del seguro en la posición
E. Al activar otra vez el gatillo, el cargador
será expulsado de la caja hacia atrás.



CARGAR

ES



ATENCIÓN

Sólo use munición de fogueo o de gases lacrimógenos cal. 6 mm munición de fogueo Flobert. Mantenga siempre puesto el seguro de la pistola mientras realiza las operaciones de carga, descarga y desmontaje Además, mantenga la boca del cañón siempre apuntando hacia abajo.



❶ Extraiga el cargador vacío.



❷ Plegue hacia arriba el portacartuchos.

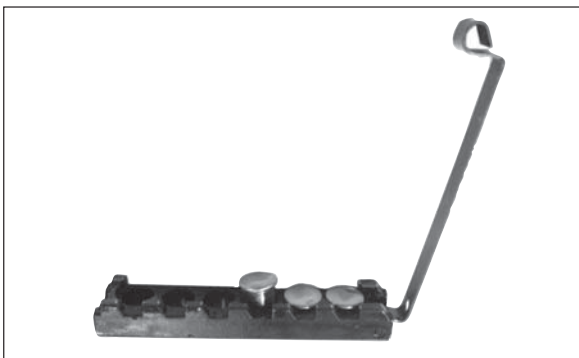

❸ Colocar munición cal. 6mm Flobert en el cargador.

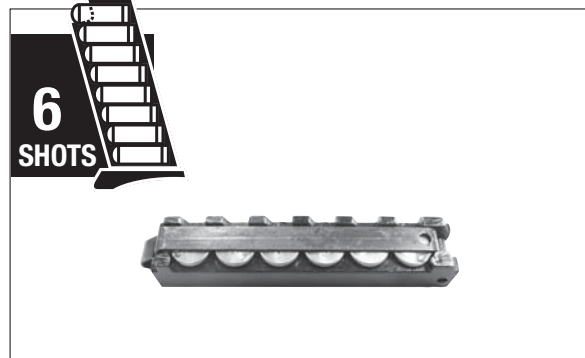

❹ Cerrar el portacartuchos



❺ Introducir el cargador lleno, partiendo de la parte delantera, en el canal del cargador de la pistola hasta que encaje.



DISPARO DE LA MUNICIÓN DE FOGUEO / MUNICIÓN DE GASES LACRIMÓGENOS

ES

Sistema de doble acción (doble acción)

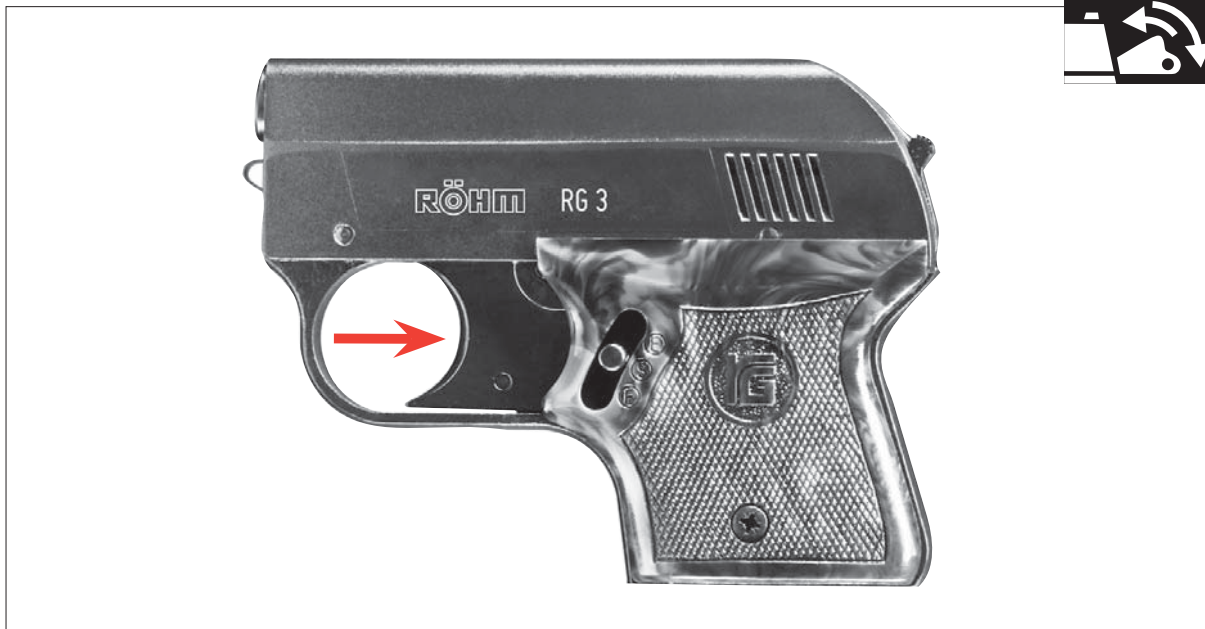
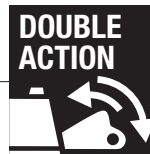

Accione el gatillo.



EXTRAER CASQUILLOS DISPARADOS



Girar el perno de carga de la tapa del cargador, plegar hacia arriba el portacartuchos del cargador y extraer los casquillos con el perno de carga.



DISPARAR MUNICIÓN DE SEÑALES

ES

Usar solamente tambores de munición con la siguiente caracterización PTB:

PTB
33

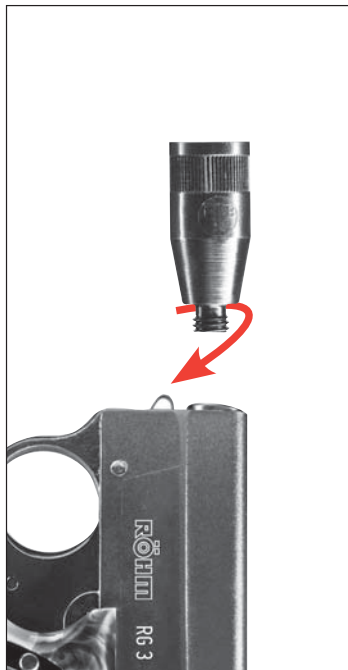

Atornillar el tambor para munición en el cañón. Cargar el arma con la munición de fogeo.



Introducir primero la munición de señales, con el extremo del cartucho (negro) abierto, en el tambor para munición.



A la hora de disparar mantenga el arma verticalmente por encima de la cabeza.



ATENCIÓN

El tirador deberá mantener una distancia de por lo menos 2 m respecto a las personas presentes.



ACCESORIOS

ES

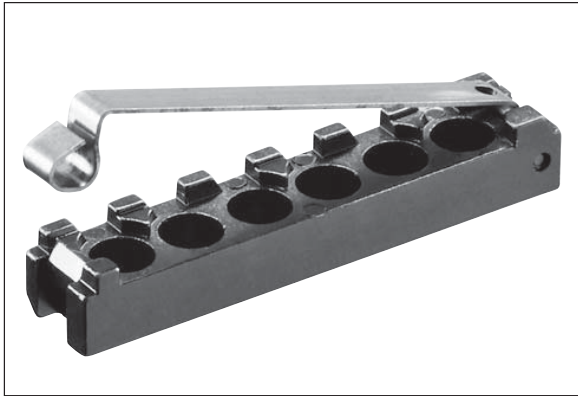

Cargador



Caja de plástico izquierda



Cacha de plástico derecha

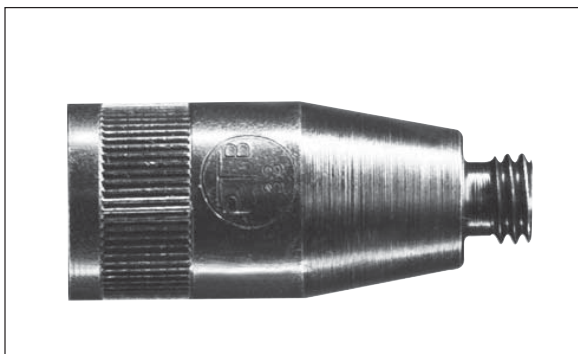

Tambor para munición PTB N°: 33

1



GÜVENLİK BİLGİLERİ

2



BAKIM

3



PARÇALARIN ADLANDIRILMASI

4



KULLANIM



SAFE WEAPON HANDLING

TR

Silahınızın doğru ve güvenli şekilde kullanımına vakıf olmanız gerekmektedir. Güvenli silah atmanın ana kurallarına bakıldığında, silah ile her türlü temasın kullanım olarak anlaşıldığını göz önünde bulundurun.

- Her silaha sanki dolu imiş gibi muamele yapın.
- Silahı doldurma esnasında her zaman yanlışlıkla ateş alamayacağı şekilde emniyete alın.
- Parmağınızı her zaman tetikten uzak tutun ve sadece ateşlemek için tetiğin üzerine koyun.
- Sadece bu silahla kullanılması öngörülen mühimmatı kullanın.
- Namlusunu her zaman emniyetli bir yöne tutun.
- Hiçbir zaman silahı dolu halde taşımayın. Sadece atış yapacağınız zaman doldurun.
- Silahı hiç bir zaman insanların veya hayvanların üzerine doğrultmayın.
- Atış yapmadan önce hedefin ve çevredeki alanın güven altında olduğundan emin olun.
- Silahı taşımadan önce ve başka birinden teslim aldıktan hemen sonra daima dolu olup olmadığını kontrol edin.
- Tökezlediğiniz veya düştüğünüz durumlarda bile namlunun yönünü kontrol edebileceğinizden emin olun.
- Emniyet açısından atış sırasında koruyucu gözlük kullanılmalıdır.
- Silahı daima boş olarak ve emniyetli halde, mühimmattan ayrı olarak ve yetkisiz kişilerin (eğitimi ve deneyimi olmayanların, 18 yaşın altında kişilerin) izinsiz erişemeyeceği şekilde saklayın.
- Bu silahı kullanım kılavuzu ile beraber sadece 18 yaşından büyük ve bu silahın kullanımına vakıf olan kişilere verebilirsiniz.
- Silahların üzerinde yapılacak her türlü değişiklik veya tamirat sadece uzman şirketler veya bir silah ustası tarafından yapılmalıdır.
- Hiçbir zaman dolu bir silahı elden bırakmayın.
- Sadece boşaltılmış silahları başka kişilere verin.
- Kuru sıkı silahlarla ateş edilmesine sadece aşağıdaki durumlarda izin verilmiştir (daha fazla bilgi için ülkenizde yürürlükte bulunan silah yasasını dikkate alınız):
 - Tehlikeyi uzaklaştırmak için ve kurtarma talimlerinde
 - Meşru müdafaa durumlarında ve ızdırar halinde
 - Mesken sahipleri tarafından veya onların izni ile duvarla çevrili arazilerde



DİKKAT

İşbu kullanım kılavuzunda verilen yasa bilgileri sadece Almanya için geçerli olup diğer ülkeler için geçerli değildir. Lütfen bulunduğunuz ülkenin silah yasasına riayet edin!



GARANTİ

Satış tarihinden sonraki yasal süre içinde, silahta oluşan arıza kendi hatanızdan dolayı oluşmamış ise, Umarex Sportwaffen GmbH & Co. KG şirketi silahınızı ücretsiz olarak tamir eder veya karşılığında yenisini verir. Silahı yetkili bir satıcıya götürün, ona sorunu anlatın ve satış belgesini sunun.

Umarex Sportwaffen GmbH & Co. KG şirketi tarafından üretilen kuru sıkı silahlar / tahriş edici madde ve işaret silahları Fizik ve Teknik ile ilgili Federal Daire'nin (PTB) ruhsatlandırma şartlarına, federal yasaya, CIP talimatlarına ve de Umarex GmbH & Co. KG şirketinin silah tekniği konusundaki deneyimlerine dayanılarak üretilmektedir.

Bu sebeple, eğer bu silah yurt dışına ihraç edildikten sonra o ülkenin hükümlerine uymadığı tespit edilirse ve sahibi/alıcısı bundan dolayı hukuki sorunlarla ve bunların sonuçları ile karşılaşır, şirketimiz hiç bir mesuliyet kabul etmemektedir.



DİKKAT

Hem kendinizin hem de başkalarının emniyeti için, silah ile ilk atış denemesine kalkışmadan önce bu kullanım kılavuzunu tam olarak ve itina ile okuyun. Bu silahları satın alan veya sahibi olan kişiler kuru sıkı tabancaların / tahriş edici madde ve işaret tabancalarının kullanılması ve bulundurulması ile ilgili tüm kurallara uymakla yükümlüdürler. Bu silah üzerinde yapılacak her türlü değişiklik silah hukukunca yapılan sınıflandırmanın değişmesine neden olabilir ve bu sebeple yasaktır. Üreticinin vermiş olduğu garanti bu durumda geçerliliğini derhal kaybeder.

Bu kuru sıkı tabanca / tahriş edici madde ve işaret tabancası 18 yaş ve üstü kişiler tarafından serbestçe satın alınabilir.



BAKIM

Her kullanımdan sonra silahınıza bakım yapın. Silah yağı, temizleme fırçası ve yumuşak bir bez vasıtası ile fişek yatağını, fişek yatağı rampasını ve şarjör dudaklarını temizleyin.

TAMİR

Kusursuz çalışmayan bir silah tehlikelidir. Bir silahı kendi başınıza tamir etmeniz zordur ve yanlış şekilde monte edilmesi tehlikeli işlevsel bozukluklara neden olabilir.



DİKKAT

Silahınızı sadece yetkili bir uzman satıcı/silah ustası tarafından kontrol ve tamir ettirin.

TEKNİK ÖZELLİKLER

Sistem:	Kuru sıkı tabanca / tahriş edici	Genişliği:	24,5 mm
Tetik:	Double Action Only	Yüksekliği:	80 mm
Mühimmat:	Kuru sıkı / Tahriş edici madde mermileri	Ağırlığı:	335 g
Kalibre:	cal. 6 mm Flobert	Şarjör kapasitesi:	6 atış
Uzunluğu:	105 mm	Emniyeti:	manüel



PARÇALARIN ADLANDIRILMASI / TEKNİK ÖZELLİKLER

TR

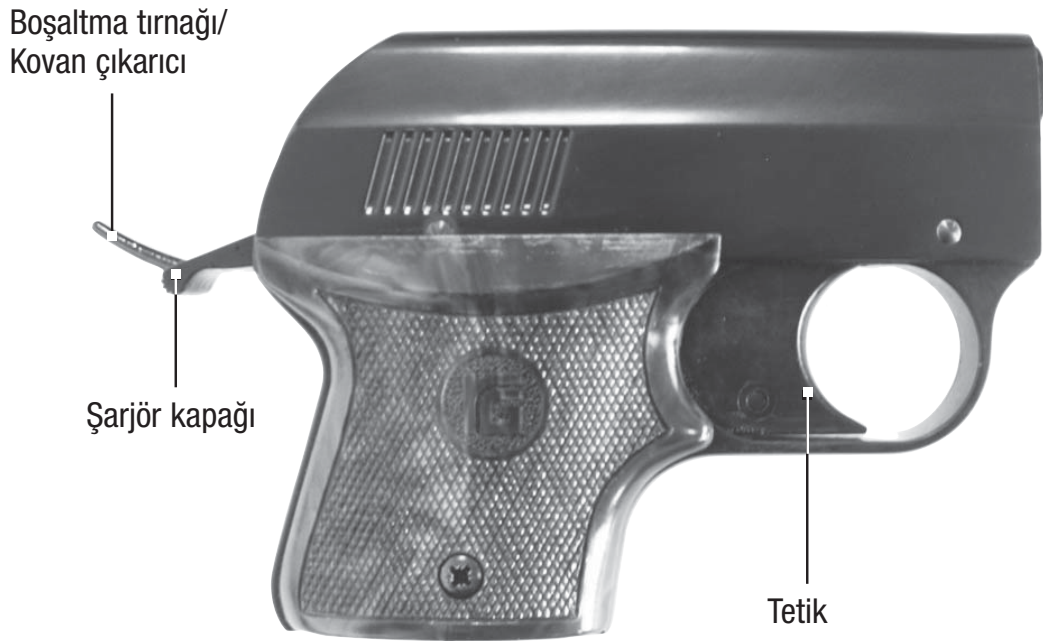



EMNİYET / ATIŞ / BOŞALTMAK

TR



DİKKAT

Silahı sadece, emniyetli halde iken elinize alın.
Namlunun her zaman güvenli bir yöne doğrultulmuş olduğuna dikkat edin.

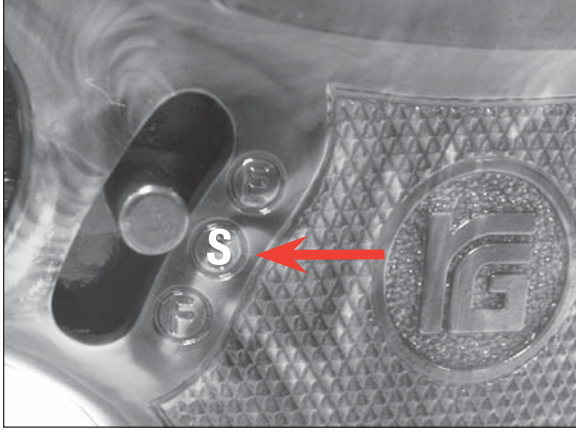

Emniyete almak

Emniyet kolunu **S** konumuna getirin.

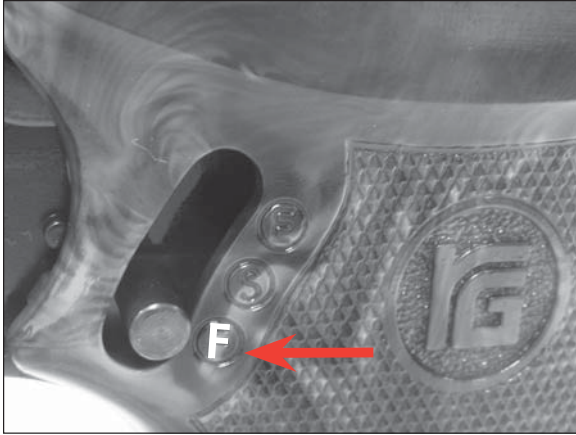

Atış

Emniyet kolunu **F** konumuna getirin.
Tetiği sonuna kadar çekin. Tetik başlangıç konumuna geri döndükten sonra tabanca atışa hazırdır. 6 atış sonunda şarjör boşalır, bir kere daha tetik çekildiğinde şarjör yerinden çıkar.

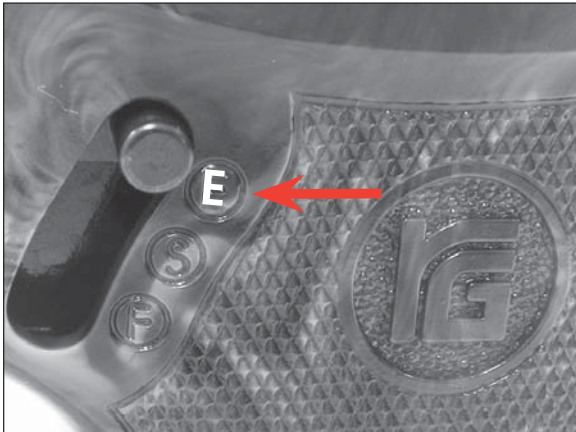

Boşaltmak

Emniyet kolunu **E** konumuna getirin.
Tetiğin çekilmeye devam edilmesiyle şarjör yuvasından arkaya doğru dışarı atılır.



DOLDURMA

TR



DİKKAT

Sadece cal. 6 mm Flobert kuru sıkı fişek kullanın.
Tabancayı sadece emniyetli haldeyken doldurun, boşaltın veya sökün.
Bu sırada namluyu her zaman yere doğru tutun.



❶ Boş şarjörü alın.



❷ Şarjördeki fişek tutucuyu yukarıya kaldırın.

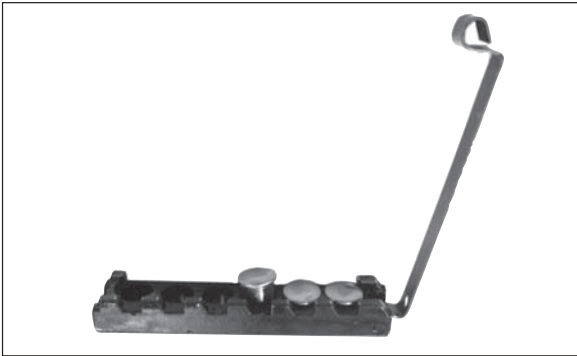

❸ Şarjöre cal. 6mm Flobert fişek yerleştirin.

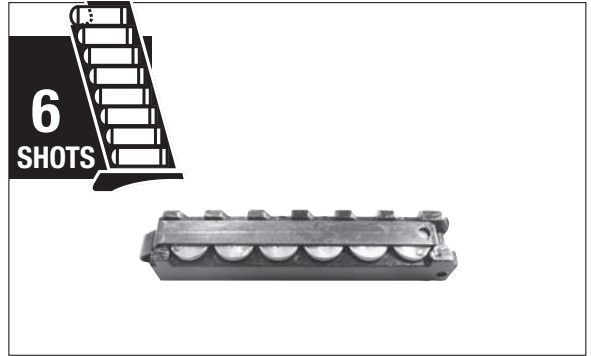

❹ Tutucuyu kapatın.



❺ Dolu şarjörü önden tabancanın şarjör yuvasına geçirin ve dayanıncaya kadar ilerletin.



KURU SIKI / TAHRİŞ EDİCİ MADDE FİŞEĞİ İLE ATIŞ

TR

Otomatik kurmalı tetik sistemi - (sadece çift hareketli tipte)

DOUBLE
ACTION



Tetiği çekin.



ATILAN MERMİ KOVANLARININ ÇIKARILMASI

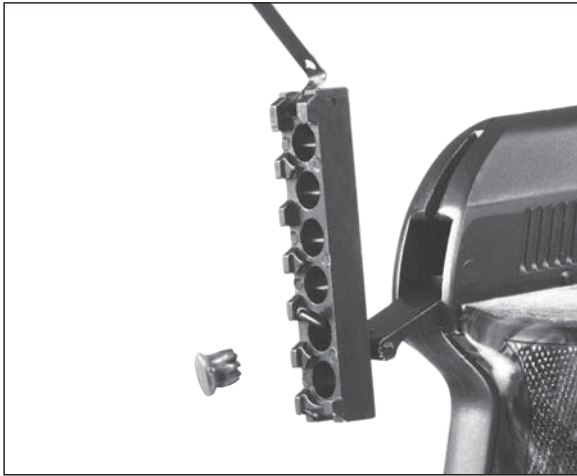

Şarjör kapağındaki boşaltma tırnağını çıkarın, şarjördeki mermi tutucuyu kaldırın ve boşaltma tırnağıyla kovanları dışarı itin.



İŞARET FİŞEĞİ İLE ATIŞ

TR

Sadece aşağıda belirtilen PTB (Fizik ve Teknik ile ilgili Federal Daire) işaretli atış kutularını kullanın:

PTB
33

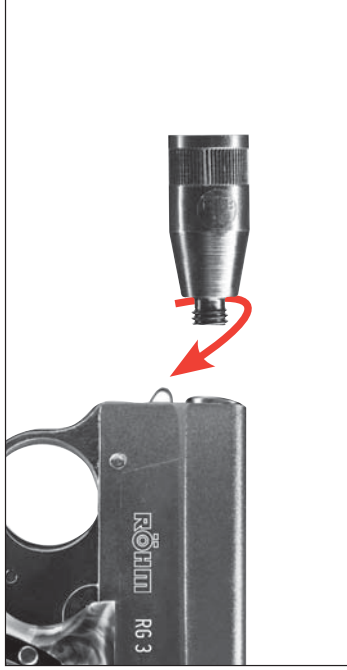

Atış kutusunu namluya vidalayın.
Silahı kuru sıkı fişeklerle doldurun.

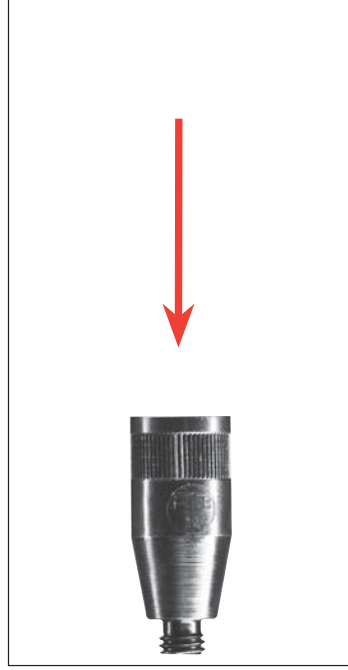

İşaret fişeklerini kovanın açık (siyah) ucu önde olacak şekilde atış kovanına yerleştirin.



Atış yaparken silahı dikey olarak başınızın üstünde tutun.



DİKKAT

Atış yaparken etraftaki kişilere en az 2 m mesafe bulunduğuna dikkat edin.



AKSESUAR

TR

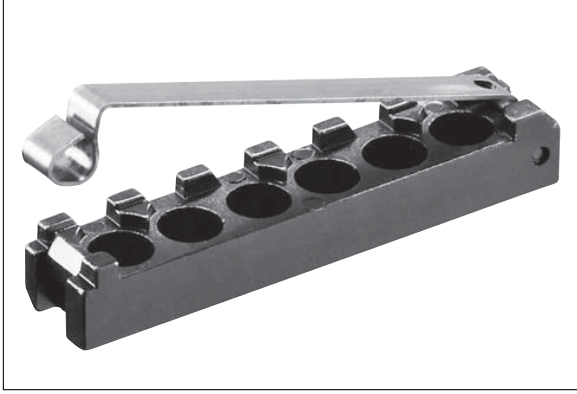

Şarjör



Kabza kapağı sol



Kabza kapağı sağ

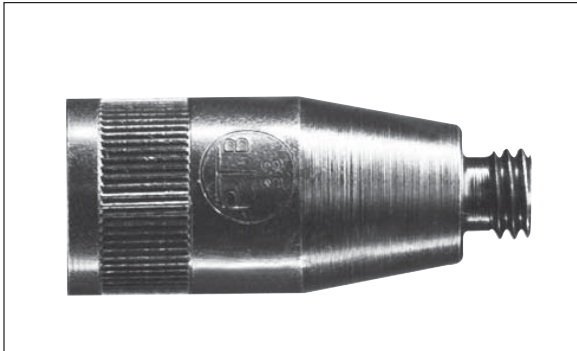

Atış kutusu PTB-No.: 33

1



УКАЗАНИЯ ПО ТЕХНИКЕ БЕЗОПАСНОСТИ

2



УХОД

3



НАИМЕНОВАНИЕ ДЕТАЛЕЙ

4



ТЕХНИЧЕСКОЕ ОБСЛУЖИВАНИЕ



БЕЗОПАСНОЕ ОБРАЩЕНИЕ С ОРУЖИЕМ

RU

Необходимо знать, как правильно и безопасно обращаться с оружием. С точки зрения основных правил безопасной стрельбы помните, что обращением является любое прикосновение к оружию.

- Обращайтесь с любым оружием так, как если бы оно было заряжено.
- При зарядании всегда ставьте оружие на предохранитель во избежание непроизвольного выстрела.
- Никогда не держите палец на спусковом крючке; класть палец на спусковой крючок только для производства выстрела.
- Используйте только предусмотренные для этого оружия боеприпасы.
- Всегда держите ствол оружия в безопасном направлении.
- Транспортировка оружия в заряженном состоянии строго запрещена. Всегда заряжайте его непосредственно перед выстрелом.
- Никогда не направляйте оружие на людей или животных.
- Перед выстрелом убедитесь в безопасности цели и выстрела для окружающих.
- Всегда проверяйте, чтобы оружие не было заряжено при транспортировке или если принимаете его от другого лица.
- Убедитесь в том, что Вы способны контролировать направление ствола оружия при падении или если споткнетесь.
- В целях безопасности при стрельбе необходимо надевать защитные очки.
- Всегда храните оружие в разряженном виде и на предохранителе, отдельно от патронов, в местах, недоступных посторонним (лицам, не обученным специально, детям, лицам до 18 лет).
- Передача оружия возможна только вместе с инструкцией по эксплуатации и только лицам старше 18 лет, которые в точности знают, как обращаться с этим оружием.
- Любые изменения в конструкции оружия или его ремонт должны производиться только в специализированных фирмах или оружейным мастером.
- Никогда не выпускайте из рук заряженного оружия.
- Передача оружия другому лицу возможна, только если оружие разряжено.
- Стрельба из оружия отпугивающего действия разрешается только (более подробно смотри закон об оружии, действующий в Вашей стране):
 - для предотвращения опасности и во время спасательных учений
 - в случаях необходимой самообороны и в чрезвычайной ситуации
 - лично домовладельцем или законным владельцем оружия - с согласия домовладельца.



ВНИМАНИЕ

Названные в данной инструкции по эксплуатации законы относятся исключительно только к Германии. Пожалуйста, соблюдайте соответствующий закон об оружии в Вашей стране!



ГАРАНТИЯ

Фирма Umarex Sportwaffen GmbH & Co. KG бесплатно произведет ремонт или замену оружия в течение предусмотренного законом срока со дня покупки, если неисправность возникла не по собственной вине владельца. Передайте оружие лицензированному продавцу, опишите проблему и приложите документ, подтверждающий покупку.

Изготовленное фирмой Umarex Sportwaffen GmbH & Co. KG оружие отпугивающего, раздражающего и сигнального действия выпускается в соответствии с регламентирующими их применение предписаниями Федерального физико-технического ведомства (ФФТВ), федеральным законом, предписаниями Постоянной международной комиссии (CIP) и оружейно-техническим ноу-хау фирмы Umarex Sportwaffen GmbH & Co. KG.

Таким образом, мы не берем на себя ответственность за то, если это оружие после экспорта за рубеж не соответствует действующим там правовым предписаниям, и у владельца/продавца из-за этого возникнут юридические трудности и последствия.

В России гарантийный срок продолжаться шесть месяцев.



ВНИМАНИЕ

В целях Вашей собственной безопасности и безопасности других внимательно прочтите всю инструкцию по эксплуатации, прежде чем предпринять первую попытку производства выстрела. Покупатель и владелец оружия обязаны соблюдать все правила пользования и владения оружием отпугивающего, раздражающего и сигнального действия. Любое изменение конструкции этого оружия может привести к изменению категории оружия и потому недопустимо. В этом случае гарантийные обязательства производителя автоматически теряют силу.

Свободная продажа настоящего пистолета отпугивающего / раздражающего / сигнального действия возможна лицам старше 18 лет.



УКАЗАНИЯ ПО МЕРАМ БЕЗОПАСНОСТИ



УХОД

RU

УХОД

Техническое обслуживание оружия проводить после каждого использования. При помощи оружейного масла, ёршика и лоскута мягкой ткани прочистите патронник, дно канала ствола и загибы для направления патронов в патронник.

РЕМОНТ

Оружие, у которого механизмы не работают исправно, опасно. Сложно самостоятельно отремонтировать оружие, и его неправильная сборка может привести к опасным отказам.



ВНИМАНИЕ

Отдавайте оружие на проверку и ремонт только в специализированные магазины/ оружейным мастерам.

ТЕХНИЧЕСКИЕ ДАННЫЕ

Система:	Пистолет отпугивающего / раздражающего / сигнального действия	Длина:	105 mm
Спуск:	Double Action Only	Ширина:	24,5 mm
Патроны:	холостые/ раздражающего действия	Высота:	80 mm
Калибр:	cal. 6 mm Flobert	Вес:	335 г
		Емкость магазина:	6 выстрелов
		Предохранитель:	ручной



НАИМЕНОВАНИЕ ДЕТАЛЕЙ / ТЕХНИЧЕСКИЕ ДАННЫЕ

RU





ПОСТАНОВКА НА ПРЕДОХРАНИТЕЛЬ / СТРЕЛЬБА / РАЗРЯЖЕНИЕ

RU



ВНИМАНИЕ

Обращайтесь с оружием только в том случае, если оно стоит на предохранителе. Всегда следите за тем, чтобы ствол оружия был направлен в безопасную сторону.

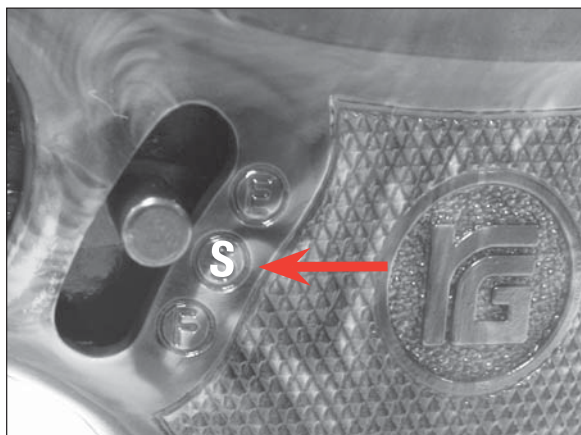

Постановка на предохранитель

Передвинуть рычаг предохранителя в середину в положение **S**.

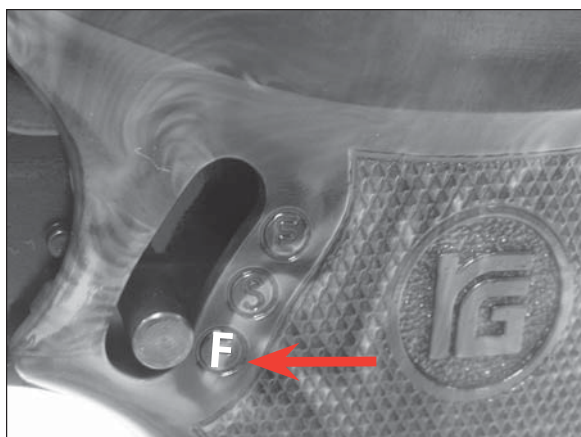

Стрельба

Передвинуть рычаг предохранителя в положение **F**. Нажать на спусковой крючок до конца. После возврата спускового крючка в исходное положение пистолет вновь готов к стрельбе. После 6 выстрелов магазин пустой, при еще одном нажатии на спусковой крючок магазин выпадает.

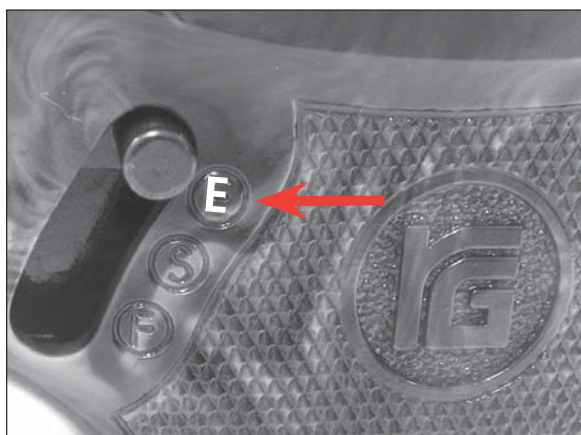

Разряжение

Передвинуть рычаг предохранителя в положение **E**. При еще одном нажатии спускового крючка до конца магазин выдвигается назад из канала.



ВНИМАНИЕ

Использовать только холостые патроны или патроны раздражающего действия калибра 6 мм Flobert. Заряжать, разряжать и демонтировать пистолет только установленным на предохранитель. При этом держать дульный срез всегда вниз.



❶ Извлечь пустой магазин.



❷ Держатель патронов на магазине откинуть вверх.

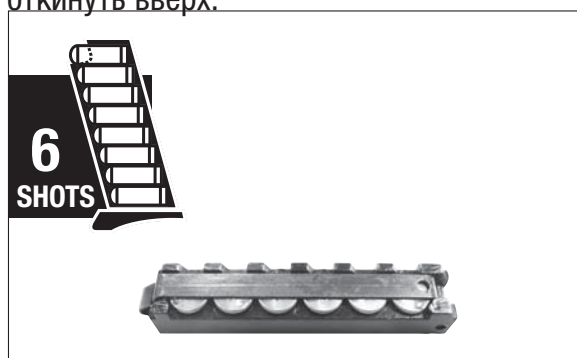
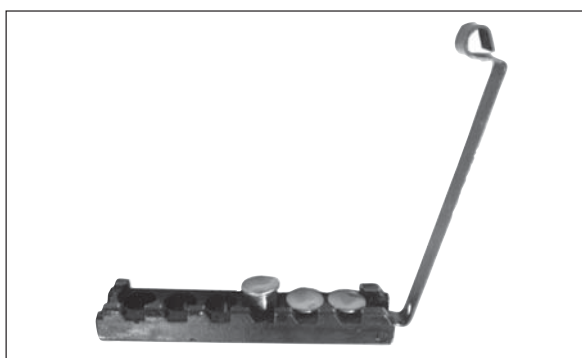

❸ Вставить в магазин патроны калибра 6 мм Flobert.

❹ Закрыть держатель.



❺ Снаряженный магазин ввести в канал пистолета до фиксации.



СТРЕЛЬБА ПАТРОНАМИ СИГНАЛЬНОГО / РАЗДРАЖАЮЩЕГО ДЕЙСТВИЯ

RU

Система взвода курка - (только двойного действия)

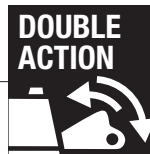

Нажать на спусковой крючок.



УДАЛЕНИЕ ГИЛЬЗ ОТСТРЕЛЯННЫХ ПАТРОНОВ



Откинуть разрядный штифт на защелке магазина, повернуть вверх держатель патронов на магазине и разрядным штифтом вытолкнуть гильзы патронов.



СТРЕЛЬБА СИГНАЛЬНЫМИ ПАТРОНАМИ

RU

Использовать только насадку-мортирку для стрельбы сигнальными патронами с маркировкой РТВ (федерального физико-технического ведомства):

РТВ
33

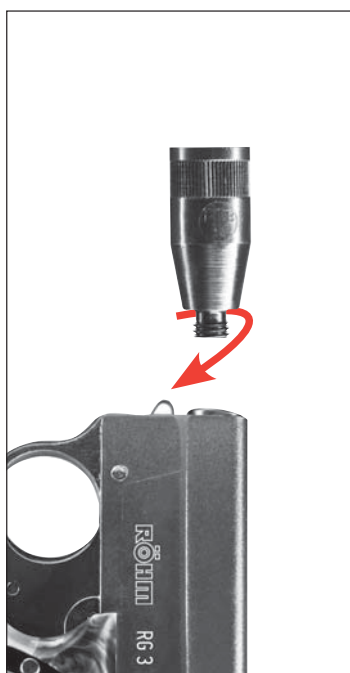

Ввернуть насадку-мортирку в ствол. Зарядить оружие холостыми патронами.

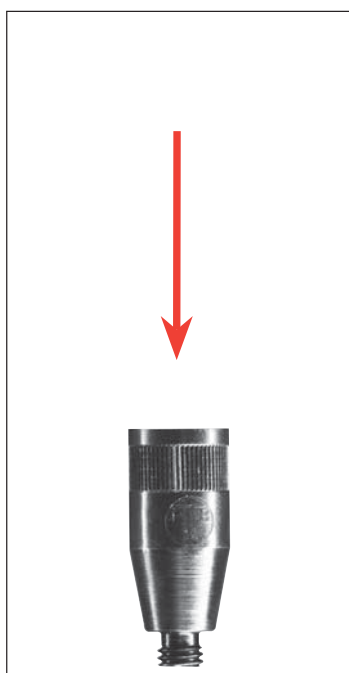

Сигнальный патрон сначала вставить в насадку открытым (чёрным) концом гильзы.



При стрельбе держать оружие вертикально над головой.



ВНИМАНИЕ

Стреляющий должен находиться по отношению к окружающим на расстоянии, по меньшей мере, в 2 м.



ПРИНАДЛЕЖНОСТИ

RU

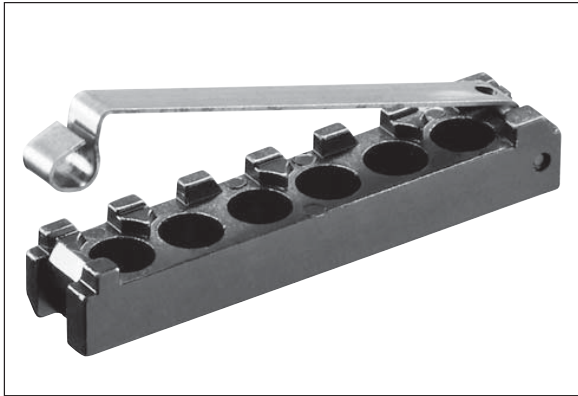

Магазин



Пластиковая накладка на рукоятку, левая



Пластиковая накладка на рукоятку,
правая

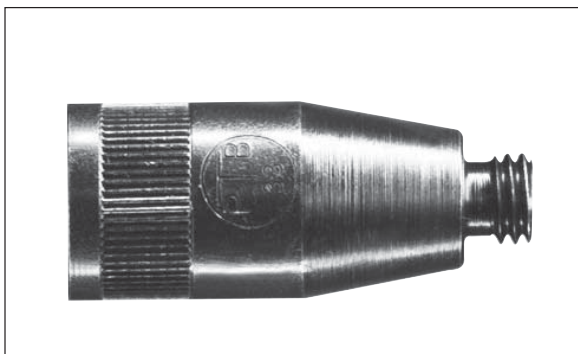

Насадка-мортирка РТВ №: 33



UMAREX®

UMAREX Sportwaffen GmbH + Co. KG

P.O. Box 27 20

D-59717 Arnsberg | Germany

Phone: +49 29 32 / 638-01

Fax: +49 29 32 / 638-222

verkauf@roehm-waffen.de | sales@roehm-guns.com

www.roehm-waffen.de | www.roehm-guns.com

We reserve the right to make color and design changes and technical improvements. No responsibility is accepted for printing errors or incorrect information.

Änderungen in Farbe und Design, sowie technische Verbesserungen, Druckfehler und Irrtum vorbehalten. Alle Angaben ohne Gewähr.

Sous réserve de modifications de couleur et de design, de modifications techniques, d'erreurs d'impression et d'erreurs en général. Informations sous toutes réserves.

Sujeto a cambios de color y diseño así como a mejoras técnicas y errores de impresión. Todos los datos sin garantía.

Renk ve tasarım üzerinde değişiklikler ve de teknik düzeltmeler, baskı hataları ve yanlışlıklar mahfuz tutulmaktadır. Verilen bilgilerden dolayı sorumluluk kabul edilmez.

Ответственность за отклонения по цвету и дизайну, а также технические исправления, опечатки и ошибки исключена. Все сведения приводятся без гарантии.

© UMAREX Sportwaffen GmbH & Co. KG